

STEEL 鉄鋼製品



ダクタイル製Y形ストレーナ

DF-510

Ductile Iron Y-type Strainer

製品種別：ストレーナ

Category：Strainer

サイズ Size	15A~100A		
接続規格 Connection	JIS 20K RF		
主要流体名 Main Fluid	LPG	適用法規等 Applicable Regulation	認定品

仕様 Specification

設計圧力 Design Pressure	2.35MPa	設計温度 Design Temp.	-5~220℃
耐圧試験圧力 Hydrostatic Testing Pressure	3.9MPa	気密試験圧力 Leakage Testing Pressure	2.35MPa

材質 Material

Body	FCD-S		
Bonnet	S25C		
Screen	SUS304 40メッシュ		

サイズ (Size)	d	D	L	H	重量 Weight	製品コード Code
15A	15	95	130	80	2.5 kg	DF-510-25-015
20A	20	100	140	80	2.9 kg	DF-510-25-020
25A	25	125	160	95	4.8 kg	DF-510-25-025
40A	40	140	210	125	8.3 kg	DF-510-25-040
50A	50	155	250	155	10.5 kg	DF-510-25-050
80A	80	200	320	240	26.5 kg	DF-510-25-080
100A	100	225	380	280	31.5 kg	DF-510-25-100

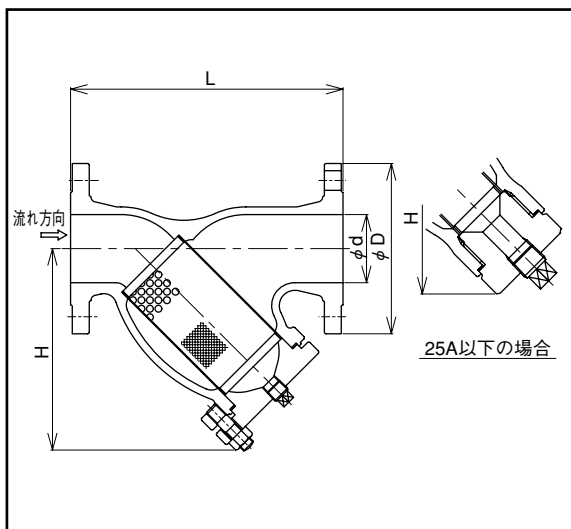

S

STEEL 鉄鋼製品



鋳鋼製フランジ形ストレーナ

Cast Steel Strainer

製品種別：ストレーナ

Category：Strainer

PV-813GT

PV-813GY

PV-813EY

サイズ Size	15A~250A	主要流体名 Main Fluid	NH ₃ etc.
接続規格 Connection	JIS 20K RF, SW, BW, etc.	適用法規等 Applicable Regulation	認定品 設備品

仕様 Specification

設計圧力 Design Pressure	2.4MPa	設計温度 Design Temp.	
耐圧試験圧力 Hydrostatic Testing Pressure	3.9MPa	気密試験圧力 Leakage Testing Pressure	2.4MPa

材質 Material

Body	SCPH2	SCS13	SCPL1
Bonnet	SUS304 or SCPH2	SUS304 or SCS13	LF20 or SCPL1
Screen	SUS304	SUS304	SUS304
Gasket	PTFE	PTFE	PTFE
Design Temp.	-5~120℃	-30~120℃	-45~120℃

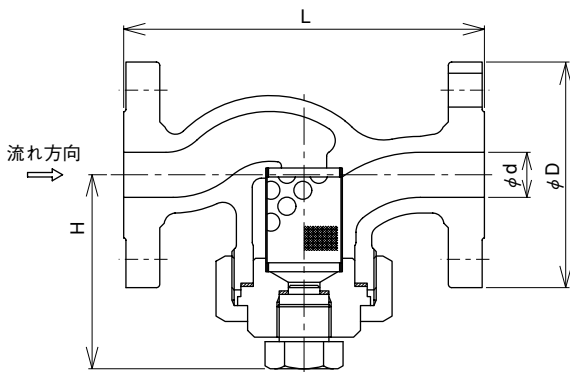

15A~20A

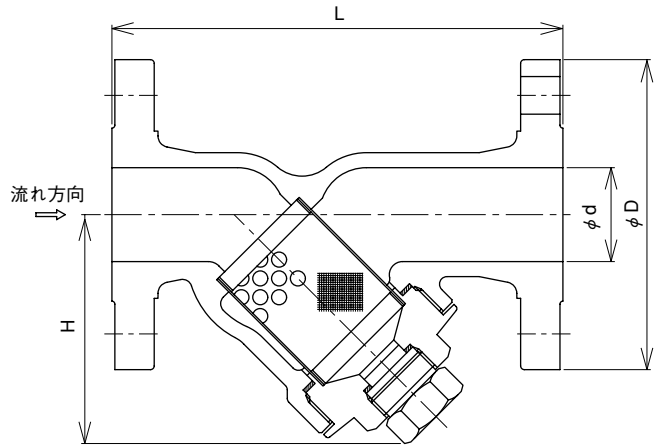

25A~50A

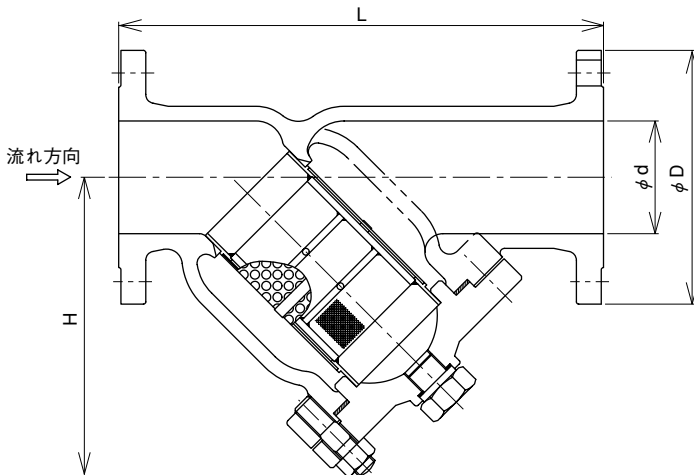

65A~250A

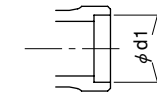

ソケットウェルド

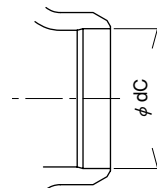

バットウェルド

※受注生産品